

Flexible silicone rubber ribbons for heat tracing



Safety instructions for all industrial silicone rubber ribbon heaters described in this catalogue section

General conditions

- 1- Read the user manual before any use
- 2- Protect the power supply circuit by a differential circuit breaker of 20mA sensitivity, with rating adapted to the model that must be connected to it.
- 3- This power supply supply circuit must be carried out by a qualified electrician and according to the local standards in force.
- 4-The earth circuit must be compliant and connected.
- 5- Check that power supply voltage is the same than printed on the heater.
- 6- Don't use silicone rubber heaters with surface power higher than 0.2 W/cm² on plastic surfaces.
- 7- The heater must be disconnected during installation or de-installation.
- 8-The heater must be stored in a dry place and protected from rodents and other animals during periods when it is not used.
- 9- Do not cut or punch the surface
- 10- Silicone heaters are not suitable for prolonged exposure to oils.
- 11- These devices are not suitable for use in flammable or explosive areas.

Additional instructions for heating ribbons

- 12- Do not operate above rated safety temperature of the product. (This temperature must be checked before connecting the device).
- 13- The silicone heater must be in contact with the surface to be heated, without superimposing heating parts. The superposition of two heating parts doubles the surface power and can cause melting of the silicone heater and initiate a fire in the most severe cases.
- 14- Heated surface must be clean and not greasy.
- 15- Position the silicone heater so that it is in perfect contact with the largest possible surface to be heated.
- 16- Do not wrap on handles, fittings, taps, legs, plugs, rivets, screws or any surface irregularity.
- 17- Never immerse the heater in liquids or water. It is not immersion proof. If it must be cleaned, disconnect from power supply before cleaning and clean it with soft tissue.
- 18- Do not use on square or rectangular pipes with sharp angles. Angles must have a radius greater than 20mm.

NT3000SPH037A



Heating flat ribbons in silicone, width 15 mm, maximum length 10m, for electric tracing. **Without thermostats.**

Walls material	Maximum temperature	Tightening	Thermostat	Silicone thickness (mm)	Type
Metal or plastic	200°C	Optional adhesive side	Without thermostat, but K thermocouple in option	1,6 2,5	9AS

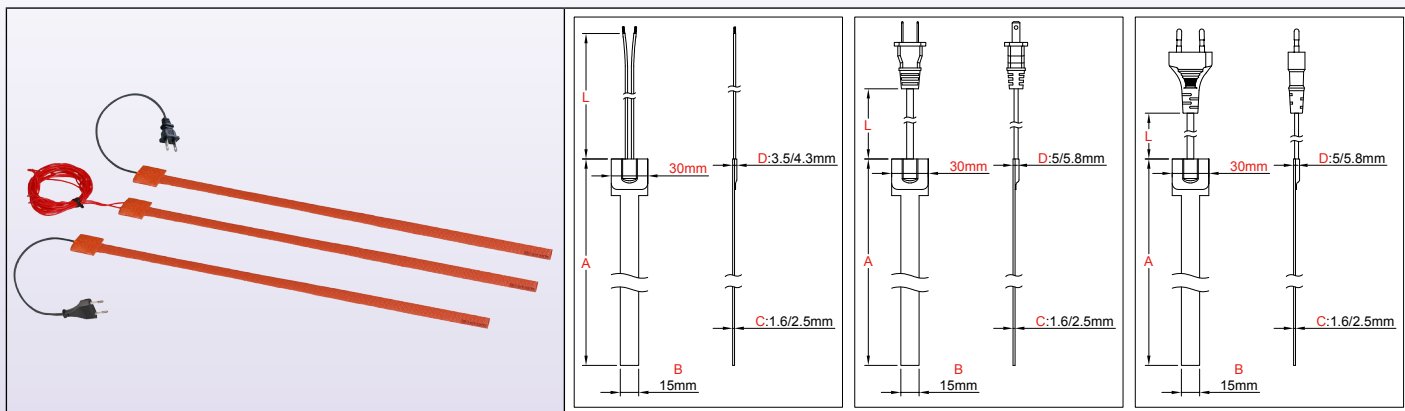

Main features

Silicone rubber ribbons are made of fiberglass reinforced laminated silicone rubber sheets, vulcanized together through heat and high pressure on both sides of an embedded specially formed heating wire element. Fiberglass-reinforced silicone rubber gives the heater dimensional stability without sacrificing flexibility. Silicone is used because of its high temperature resistance (Permanent temperature up to 200°C /390°F), high thermal conductivity ($\sim 7 \cdot 10^{-4} \text{W/cm.K}$) and good electrical insulation properties ($\sim 12 \text{KV/mm}$)

This series is distinguished by its small width allowing it to be wound around pipes for electrical tracing applications. Heating elements of this series can be made with constant power when the temperature rise, or with positive temperature coefficient reducing the power when the temperature rises.

Other general particularities of these heaters are:

- Not affected by vibration or flexing,
- Lightweight,
- Comply with UL94-VO (flame retardant) and ROHS,
- Low smoke and low Toxicity,
- Silicone is non-toxic, and moisture and chemical resistant,
- Very thin profile

Main Applications

Some typical applications examples are:

Provide process temperature maintenance or avoid freezing to metallic and plastic piping, gutters, valves, pumps, water meters. These ribbons are usually wrapped around the pipe or equipment, but can also be mounted longitudinally. **Unlike self-regulating heating cords using PTC plastic compounds, they are not subject to a drift in their characteristics over time**, and they exist in a wider surface power range.

Technical Features

Clamping: Installation is usually done on pipes, with fiberglass reinforced tape, or using adhesive heater.

Length (Dimension A): 2.5m, 5m, 10m

Width: 15 mm

Silicone foil minimum bending radius: 3.2 mm (0.125")

Ingress protection: IP65.

Minimum ambient temperature: -10°C (+15°F)

Voltage: 220-240VAC.

Power tolerance: $\pm 10\%$ at 20°C

Temperature control: No thermostat or high limit switch available on these products (Width is not enough for them). K thermocouple sensor can be embedded on request and then allows electronic temperature control. For simple applications in antifreeze applications, it is also possible to use a waterproof fixed setting thermostat control box type Y22. (See accessories in the last section of this catalogue).

Power density: from 0.1W/cm^2 (0.65W/inch^2) to 0.8W/cm^2 (5.2W/inch^2). See part numbers table.

Don't use power density higher than 0.2W/cm^2 on plastic walls. Check the surface temperature rise versus surface power density. (Table is available in the technical introduction).

Thickness of the flexible silicone foil: 1.6 or 2.5mm.

Quality control routine tests: Each heating element is 100% tested for continuity, resistance and insulation. Tests are made according to EN 60335-1 and EN 50106 standards. See technical introduction.

Dielectric Strength: 1750V AC.



Heating flat ribbons in silicone, width 15 mm, maximum length 10m, for electric tracing. **Without thermostats.**

Insulation resistance: ≥ 10 Megohms.

Operating temperature:

The temperature of the heated product is generally much lower than that of the surface and depends mainly on the surface power (W/cm²), the quality of the thermal contact, the viscosity, heat capacity and thermal conductivity of the heated product, the good positioning of the heater, the ambient temperature, and the fluid speed inside the pipe.

You can find in the technical introduction examples of the temperatures reached by silicone rubber heaters. They represent the temperature that may reach the heating element if it is not correctly installed.

Connection:

- 2 AWG18 or 0.75mm² FEP insulated wires, length 500mm (other lengths on request).

- 2 x AWG 18 or 2 x 0.75mm² cord with euro plug or UL plug (2 prongs).

Options:

- Power supply 110/115V

- Grounded mesh wire shield layer

Safety standards:

The heaters have been designed in compliance with EEC Low Voltage Directive (LVD) 2006/95/EC and EMC directive 2004/108/EC. They must be installed in accordance with all local applicable instructions, codes, and regulations.

Main curves of positive temperature coefficient alloys (self-regulating effect)

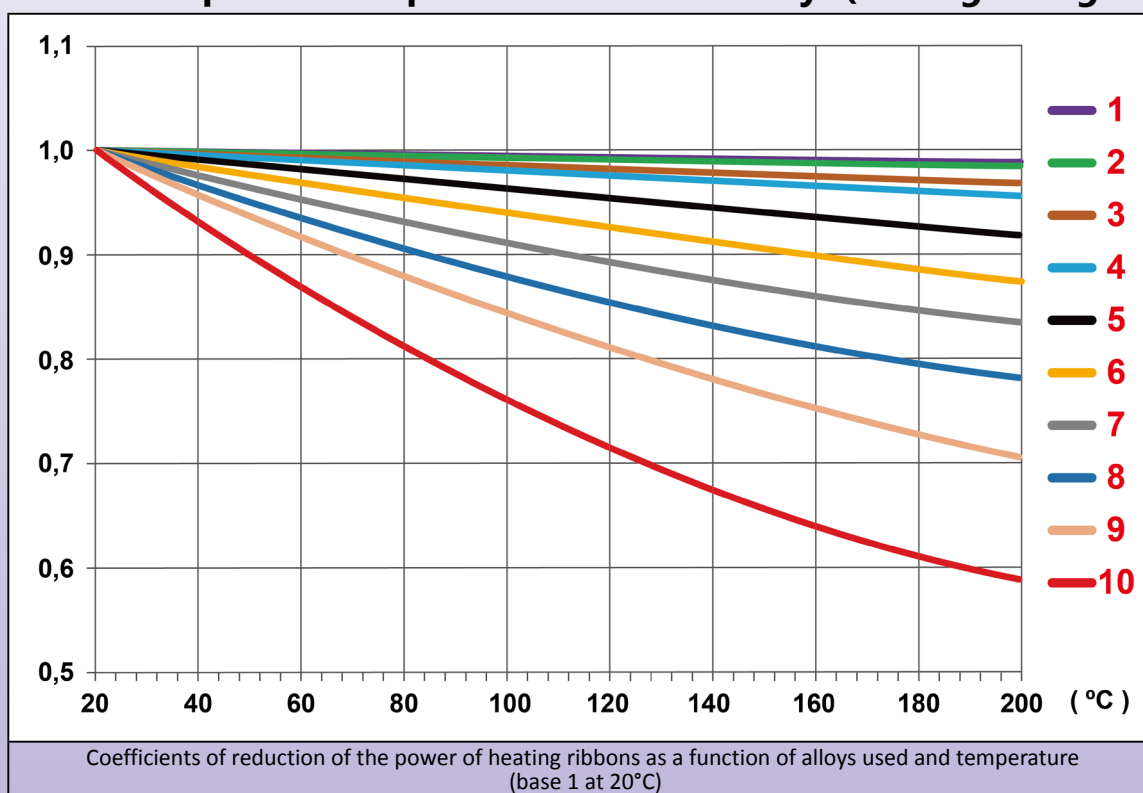

Main parts numbers in 220/240V with 3m euro plug cord *

(Surface temperatures reached versus power surface density are described in the technical introduction)

Heaters without change in power when temperature rises								
A Length m (inch)	Power density W/cm ² (W/in ²)	Total Power** Watts	Power per meter W/m	PTC curve	Part numbers without adhesive, without K sensor	Part numbers with adhesive, without K sensor	Part numbers without adhesive, with K sensor	Part numbers with adhesive, with K sensor
2,5 (98.5)	0.2 (1.3)	40	18	1	9ASA2011B5804U30	9ASF2011B5804U30	9ASA2K11B5804U30	9ASF2K11B5804U30
2,5 (98.5)	0.3 (1.9)	70	27	1	9ASA3011B5807U30	9ASF3011B5807U30	9ASA3K11B5807U30	9ASF3K11B5807U30
2,5 (98.5)	0.4 (2.6)	90	36	1	9ASA4011B5809U30	9ASF4011B5809U30	9ASA4K11B5809U30	9ASF4K11B5809U30
2,5 (98.5)	0.5 (3.2)	110	45	1	9ASA5011B5811U30	9ASF5011B5811U30	9ASA5K11B5811U30	9ASF5K11B5811U30
2,5 (98.5)	0.6 (3.9)	130	54	1	9ASA6011B5813U30	9ASF6011B5813U30	9ASA6K11B5813U30	9ASF6K11B5813U30
2,5 (98.5)	0.7 (4.5)	160	63	1	9ASA7011B5816U30	9ASF7011B5816U30	9ASA7K11B5816U30	9ASF7K11B5816U30
2,5 (98.5)	0.8 (5.2)	180	72	1	9ASA8011B5818U30	9ASF8011B5818U30	9ASA8K11B5818U30	9ASF8K11B5818U30
5 (197)	0.1 (0.65)	40	9	1	9ASA1011E0804U30	9ASF1011E0804U30	9ASA1K11E0804U30	9ASF1K11E0804U30
5 (197)	0.2 (1.3)	90	18	2	9ASA2021E0809U30	9ASF2021E0809U30	9ASA2K21E0809U30	9ASF2K21E0809U30
5 (197)	0.3 (1.9)	130	27	2	9ASA3021E0813U30	9ASF3021E0813U30	9ASA3K21E0813U30	9ASF3K21E0813U30
5 (197)	0.4 (2.6)	180	36	2	9ASA4021E0818U30	9ASF4021E0818U30	9ASA4K21E0818U30	9ASF4K21E0818U30
5 (197)	0.5 (3.2)	220	45	1	9ASA5013E0822U30	9ASF5013E0822U30	9ASA5K13E0822U30	9ASF5K13E0822U30

Because of permanent improvement of our products, drawings, descriptions, features used on these data sheets are for guidance only and can be modified without prior advice



Heating flat ribbons in silicone, width 15 mm, maximum length 10m, for electric tracing. **Without thermostats.**

Because of permanent improvement of our products, drawings, descriptions, features used on these data sheets are for guidance only and can be modified without prior advice

Heaters without change in power when temperature rises								
A Length m (inch)	Power density W/cm ² (W/in ²)	Total Power** Watts	Power per meter W/m	PTC curve	Part numbers without adhesive, without K sensor	Part numbers with adhesive, without K sensor	Part numbers without adhesive, with K sensor	Part numbers with adhesive, with K sensor
5 (197)	0.6 (3.9)	270	54	1	9ASA6013E0827U30	9ASF6013E0827U30	9ASA6K13E0827U30	9ASF6K13E0827U30
5 (197)	0.7 (4.5)	310	63	1	9ASA7015E0831U30	9ASF7015E0831U30	9ASA7K15E0831U30	9ASF7K15E0831U30
5 (197)	0.8 (5.2)	360	72	2	9ASA8026E0818U30	9ASF8026E0818U30	9ASA8K26E0818U30	9ASF8K26E0818U30
10 (394)	0.1 (0.65)	90	9	2	9ASA1021J0809U30	9ASF1021J0809U30	9ASA1K21J0809U30	9ASF1K21J0809U30
10 (394)	0.2 (1.3)	180	18	2	9ASA2022J0818U30	9ASF2022J0818U30	9ASA2K22J0818U30	9ASF2K22J0818U30
10 (394)	0.3 (1.9)	270	27	2	9ASA3023J0818U30	9ASF3023J0818U30	9ASA3K23J0818U30	9ASF3K23J0818U30
10 (394)	0.4 (2.6)	360	36	2	9ASA4025J0836U30	9ASF4025J0836U30	9ASA4K25J0836U30	9ASF4K25J0836U30
10 (394)	0.5 (3.2)	450	45	2	9ASA5025J0845U30	9ASF5025J0845U30	9ASA5K25J0845U30	9ASF5K25J0845U30
10 (394)	0.6 (3.9)	540	54	2	9ASA6025J0854U30	9ASF6025J0854U30	9ASA6K25J0854U30	9ASF6K25J0854U30
10 (394)	0.7 (4.5)	630	63	2	9ASA7025J0863U30	9ASF7025J0863U30	9ASA7K25J0863U30	9ASF7K25J0863U30
10 (394)	0.8 (5.2)	720	72	2	9ASA8025J0872U30	9ASF8025J0872U30	9ASA8K25J0872U30	9ASF8K25J0872U30

Heaters with change in power when temperature rises (PTC, positive temperature coefficient)								
A Length m (inch)	Power density W/cm ² (W/in ²)	Total Power** Watts	Power per meter W/m	PTC curve	Part numbers without adhesive, without K sensor	Part numbers with adhesive, without K sensor	Part numbers without adhesive, with K sensor	Part numbers with adhesive, with K sensor
2,5 (98.5)	0.4 (2.6)	90	36	6	9ASA4061B5809U30	9ASF4061B5809U30	9ASA4K61B5809U30	9ASF4K61B5809U30
2,5 (98.5)	0.5 (3.2)	110	45	6	9ASA5061B5811U30	9ASF5061B5811U30	9ASA5K61B5811U30	9ASF5K61B5811U30
2,5 (98.5)	0.6 (3.9)	130	54	6	9ASA6061B5813U30	9ASF6061B5813U30	9ASA6K61B5813U30	9ASF6K61B5813U30
2,5 (98.5)	0.7 (4.5)	160	63	6	9ASA7061B5816U30	9ASF7061B5816U30	9ASA7K61B5816U30	9ASF7K61B5816U30
2,5 (98.5)	0.8 (5.2)	180	72	6	9ASA8061B5818U30	9ASF8061B5818U30	9ASA8K61B5818U30	9ASF8K61B5818U30
5 (197)	0.1 (0.65)	40	9	6	9ASA4061E0804U30	9ASF4061E0804U30	9ASA4K61E0804U30	9ASF4K61E0804U30
5 (197)	0.2 (1.3)	90	18	6	9ASA4062E0809U30	9ASF4062E0809U30	9ASA4K62E0809U30	9ASF4K62E0809U30
5 (197)	0.3 (1.9)	130	27	6	9ASA4062E0813U30	9ASF4062E0813U30	9ASA4K62E0813U30	9ASF4K62E0813U30
5 (197)	0.4 (2.6)	180	36	6	9ASA4064E0818U30	9ASF4064E0818U30	9ASA4K64E0818U30	9ASF4K64E0818U30
5 (197)	0.5 (3.2)	220	45	6	9ASA5064E0822U30	9ASF5064E0822U30	9ASA5K64E0822U30	9ASF5K64E0822U30
5 (197)	0.6 (3.9)	270	54	6	9ASA6064E0827U30	9ASF6064E0827U30	9ASA6K64E0827U30	9ASF6K64E0827U30
5 (197)	0.7 (4.5)	310	63	6	9ASA7064E0831U30	9ASF7064E0831U30	9ASA7K64E0831U30	9ASF7K64E0831U30
5 (197)	0.8 (5.2)	360	72	6	9ASA8064E0836U30	9ASF8064E0836U30	9ASA8K64E0836U30	9ASF8K64E0836U30
10 (394)	0.1 (0.65)	90	9	6	9ASA1062J0809U30	9ASF1062J0809U30	9ASA1K62J0809U30	9ASF1K62J0809U30
10 (394)	0.2 (1.3)	180	18	10	9ASA20A1J0818U30	9ASF20A1J0818U30	9ASA2KA1J0818U30	9ASF2KA1J0818U30
10 (394)	0.3 (1.9)	270	27	10	9ASA30A1J0827U30	9ASF30A1J0827U30	9ASA3KA1J0827U30	9ASF3KA1J0827U30
10 (394)	0.4 (2.6)	360	36	10	9ASA40A1J0836U30	9ASF40A1J0836U30	9ASA4KA1J0836U30	9ASF4KA1J0836U30
10 (394)	0.5 (3.2)	450	45	10	9ASA50A1J0845U30	9ASF50A1J0845U30	9ASA5KA1J0845U30	9ASF5KA1J0845U30
10 (394)	0.6 (3.9)	540	54	10	9ASA60A1J0854U30	9ASF60A1J0854U30	9ASA6KA1J0854U30	9ASF6KA1J0854U30
10 (394)	0.7 (4.5)	630	63	10	9ASA70A2J0863U30	9ASF70A2J0863U30	9ASA7KA2J0863U30	9ASF7KA2J0863U30
10 (394)	0.8 (5.2)	720	72	10	9ASA80A2J0872U30	9ASF80A2J0872U30	9ASA8KA2J0872U30	9ASF8KA2J0872U30

* Cord with UL plug instead of Euro plug, replace U30 by R30 in the part number.

Output with 2 AWG18 (0.75mm²) wires,500mm long instead of euro plug with 3 meters cord, replace U30 by 450 in the part number

** Values above 800W are not compatible with this series

*** 2.5mm thickness instead 1.6mm, replace 9ASA by 9ASB or 9ASF by 9ASG in the part number.



Contact us

Web: www.ultimheat.co.th

Cat25-2-4-5

Heating flat ribbons in silicone, width 35 mm, maximum length 10m, for electric tracing.

Walls material	Maximum temperature	Tightening	Thermostat	Silicone thickness (mm)	Type
Metal or plastic	200°C	Optional adhesive side	With or without built-in fixed setting thermostat or limiter, and K thermocouple in option	1,6 2,5	9AD

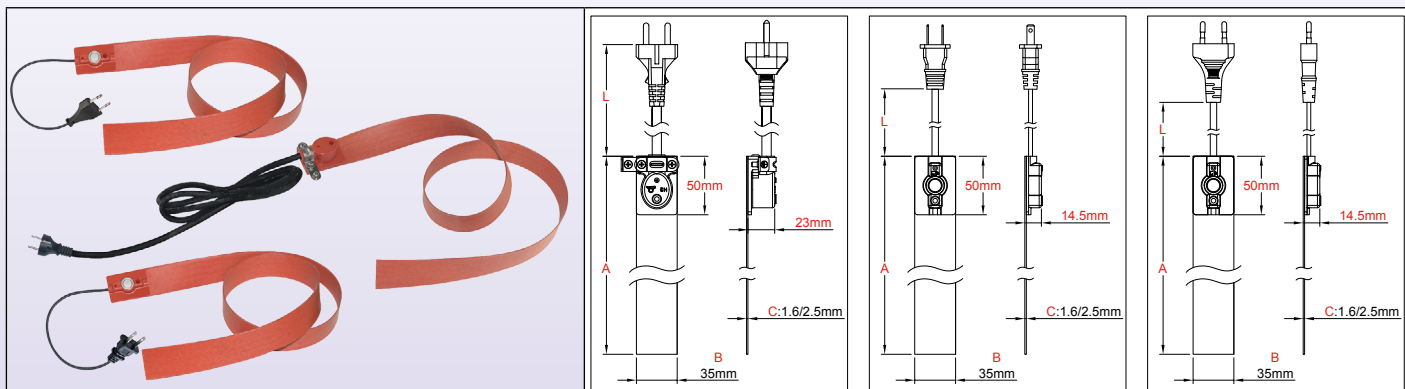

Main features

Silicone rubber ribbons are made of fiberglass reinforced laminated silicone rubber sheets, vulcanized together through heat and high pressure on both sides of an embedded specially formed heating wire element. Fiberglass-reinforced silicone rubber gives the heater dimensional stability without sacrificing flexibility.

Silicone is used because of its high temperature resistance (Permanent temperature up to 200°C /390°F), high thermal conductivity (~7 10⁻⁴ W/cm.K) and good electrical insulation properties (~12KV/mm).

This series is distinguished by its 35mm width allowing it to be wound around pipes for electrical tracing applications. This width also allows to embed fixed setting thermostats or temperature limiters on the heater surface.

Heating elements of this series can be made with constant power when the temperature rise, or with positive temperature coefficient reducing the power when the temperature rises.

Other general particularities of these heaters are:

- Not affected by vibration or flexing,
- Lightweight,
- Comply with UL94-VO (flame retardant) and ROHS,
- Low smoke and low Toxicity,
- Silicone is non-toxic, and moisture and chemical resistant,
- Very thin profile.

Main Applications

Some typical applications examples are:

Provide process temperature maintenance or avoid freezing to metallic and plastic piping, gutters, valves, pumps, water meters. These ribbons are usually wrapped around the pipe or equipment, but can also be mounted longitudinally. **Unlike self-regulating heating cords using PTC plastic compounds, they are not subject to a drift in their characteristics over time,** and they exist in a wider surface power range.

Technical Features

Clamping: Installation is usually done on pipes, with fiberglass reinforced tape, or using adhesive heater.

Length (Dimension A): 2.5m, 5m, 10m

Width: 35 mm

Silicone foil minimum bending radius: 3.2 mm (0.125")

Ingress protection: IP65.

Minimum ambient temperature: -10°C (+15°F)

Voltage: 220-240VAC.

Power tolerance: ±10% at 20°C

Temperature limiters: This series can receive many temperature limiters models. They are described in the section 7 of this catalogue

Temperature control: By fixed setting bimetal thermostat, switches on the heating at 4 +/-3°C (39+/-5°F), switches it off at 10+/-3°C (50+/-5°F), electric rating 10A 250V. K thermocouple sensor can be embedded on request and then allows electronic temperature control. In this version, the bimetal thermostat is removed.

Power density: from 0.1W/cm² (0.65W/inch²) to 0.8W/cm² (5.2 W/inch²). See part numbers table.

Don't use power density higher than 0.2W/cm² on plastic walls. Check the surface temperature rise versus surface power density. (Table is available in the technical introduction).

Because of permanent improvement of our products, drawings, descriptions, features used on these data sheets are for guidance only and can be modified without prior advice



Heating flat ribbons in silicone, width 35 mm, maximum length 10m, for electric tracing.

Thickness of the flexible silicone foil: 1.6 mm (economical types) or 2.5mm (reinforced models).

Quality control routine tests: Each heating element is 100% tested for continuity, resistance and insulation. Tests are made according to EN 60335-1 and EN 50106 standards. See technical introduction.

Dielectric Strength: 1750V AC.

Insulation resistance: ≥ 10 Megohms.

Operating temperature:

The temperature of the heated product is generally much lower than that of the surface and depends mainly on the surface power (W/cm^2), the quality of the thermal contact, the viscosity, heat capacity and thermal conductivity of the heated product, the good positioning of the heater the ambient temperature, and the fluid speed inside the pipe.

You can find in the technical introduction examples of the temperatures reached by silicone rubber heaters. They represent the temperature that may reach the heating element if it is not correctly installed.

Connection:

- 2 wires $0.75mm^2$ (AWG18), FEP insulated, length 500mm (other lengths on request).

- 2 x $0.75mm^2$ (AWG18), 3m cord, with euro plug or UL plug (2 prongs).

- Above 1250W (6A) the wire gauge becomes $1mm^2$ (AWG16)

- 3 x $1mm^2$ (3xAWG16) 3 m cord, rubber insulated, with euro or UL plug (3 prongs), or without plug.

Options:

- Power supply 110/115V

- Grounded mesh wire shield layer

Safety standards:

The heaters have been designed in compliance with EEC Low Voltage Directive (LVD) 2006/95/EC and EMC directive 2004/108/EC. They must be installed in accordance with all local applicable instructions, codes, and regulations.

Main curves of positive temperature coefficient alloys (self-regulating effect)

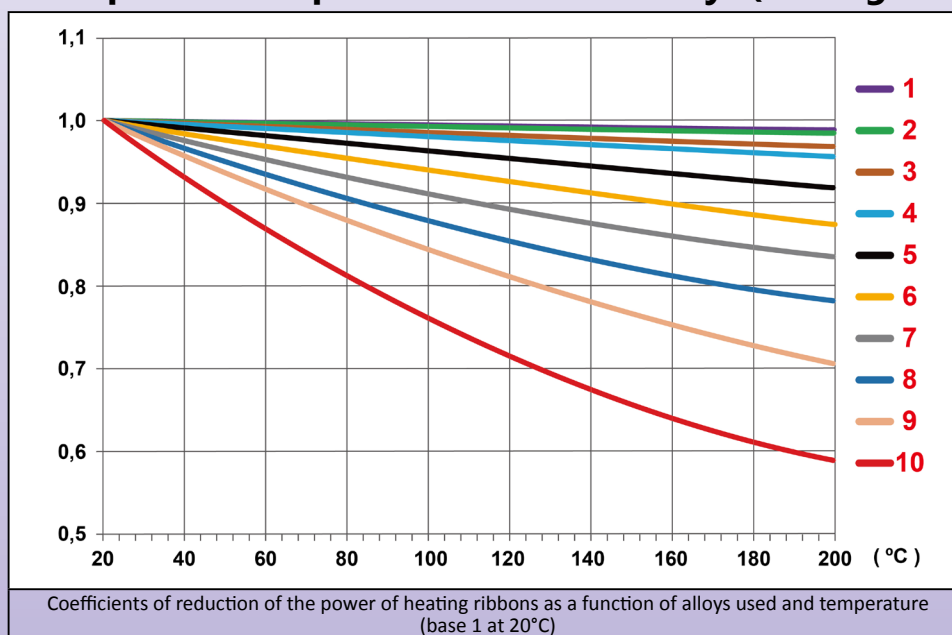

Main parts numbers in 220/240V with 3m euro plug cord *

(Surface temperatures reached versus power surface density are described in the technical introduction)

Heaters without change in power when temperature rises								
A Length m (inch)	Power density W/cm^2 (W/in^2)	Total Power** Watts	Power per meter W/m	PTC curve	Part numbers with antifreeze thermostat at 4°C, without adhesive, without K sensor	Part numbers with antifreeze thermostat at 4°C, with adhesive, without K sensor	Part numbers without antifreeze thermostat at 4°C, without adhesive, with K sensor	Part numbers without antifreeze thermostat at 4°C, with adhesive, with K sensor
2,5 (98.5)	0.1 (0.65)	60	25	1	9ADA1211B5806U30	9ADF1211B5806U30	9ADA1K11B5806U30	9ADF1K11B5806U30
2,5 (98.5)	0.2 (1.3)	120	50	1	9ADA2212B5812U30	9ADF2212B5812U30	9ADA2K12B5812U30	9ADF2K12B5812U30
2,5 (98.5)	0.3 (1.9)	180	75	1	9ADA3213B5818U30	9ADF3213B5818U30	9ADA3K13B5818U30	9ADF3K13B5818U30
2,5 (98.5)	0.4 (2.6)	250	100	1	9ADA4213B5825U30	9ADF4213B5825U30	9ADA4K13B5825U30	9ADF4K13B5825U30
2,5 (98.5)	0.5 (3.2)	310	125	1	9ADA5214B5831U30	9ADF5214B5831U30	9ADA5K14B5831U30	9ADF5K14B5831U30
2,5 (98.5)	0.6 (3.9)	370	150	1	9ADA6215B5837U30	9ADF6215B5837U30	9ADA6K15B5837U30	9ADF6K15B5837U30
2,5 (98.5)	0.7 (4.5)	430	175	1	9ADA7216B5843U30	9ADF7216B5843U30	9ADA7K16B5843U30	9ADF7K16B5843U30
2,5 (98.5)	0.8 (5.2)	500	200	1	9ADA8216B5850U30	9ADF8216B5850U30	9ADA8K16B5850U30	9ADF8K16B5850U30
5 (197)	0.1 (0.65)	120	25	1	9ADA1213E0812U30	9ADF1213E0812U30	9ADA1K13E0812U30	9ADF1K13E0812U30
5 (197)	0.2 (1.3)	250	50	2	9ADA2224E0825U30	9ADF2224E0825U30	9ADA2K24E0825U30	9ADF2K24E0825U30

Because of permanent improvement of our products, drawings, descriptions, features used on these data sheets are for guidance only and can be modified without prior advice



Contact us

Web: www.ultimheat.co.th

Cat25-2-4-7

Heating flat ribbons in silicone, width 35 mm, maximum length 10m, for electric tracing.

Heaters without change in power when temperature rises								
A Length m (inch)	Power density W/cm ² (W/in ²)	Total Power** Watts	Power per meter W/m	PTC curve	Part numbers with antifreeze thermostat at 4°C, without adhesive, without K sensor	Part numbers with antifreeze thermostat at 4°C, with adhesive, without K sensor	Part numbers without antifreeze thermostat at 4°C, without adhesive, with K sensor	Part numbers without antifreeze thermostat at 4°C, with adhesive, with K sensor
5 (197)	0.3 (1.9)	370	75	2	9ADA3224E0837U30	9ADF3224E0837U30	9ADA1K24E0837U30	9ADF3K24E0837U30
5 (197)	0.4 (2.6)	500	100	2	9ADA4224E0850U30	9ADF4224E0850U30	9ADA4K24E0850U30	9ADF4K24E0850U30
5 (197)	0.5 (3.2)	620	125	2	9ADA5225E0862U30	9ADF5225E0862U30	9ADA5K25E0862U30	9ADF5K25E0862U30
5 (197)	0.6 (3.9)	750	150	2	9ADA6226E0875U30	9ADF6226E0875U30	9ADA6K26E0875U30	9ADF6K26E0875U30
5 (197)	0.7 (4.5)	870	175	3	9ADA7236E0887U30	9ADF7236E0887U30	9ADA7K36E0887U30	9ADF7K36E0887U30
5 (197)	0.8 (5.2)	990	200	3	9ADA8236E0899U30	9ADF8236E0899U30	9ADA8K36E0899U30	9ADF8K36E0899U30
10 (394)	0.1 (0.65)	250	25	3	9ADA1233J0825U30	9ADF1233J0825U30	9ADA1K33J0825U30	9ADF1K33J0825U30
10 (394)	0.2 (1.3)	500	50	3	9ADA2235J0850U30	9ADF2235J0850U30	9ADA2K35J0850U30	9ADF2K35J0850U30
10 (394)	0.3 (1.9)	750	75	4	9ADA3246J0875U30	9ADF3246J0875U30	9ADA3K46J0875U30	9ADF3K46J0875U30
10 (394)	0.4 (2.6)	1000	100	4	9ADA4246J08A0U30	9ADF4246J08A0U30	9ADA4K46J08A0U30	9ADF4K46J08A0U30
10 (394)	0.5 (3.2)	1250	125	4	9ADA5246J08A3U30	9ADF5246J08A3U30	9ADA5K46J08A3U30	9ADF5K46J08A3U30
10 (394)	0.6 (3.9)	1500	150	5	9ADA6256J08A5U30	9ADF6256J08A5U30	9ADA6K56J08A5U30	9ADF6K56J08A5U30
10 (394)	0.7 (4.5)	1750	175	5	9ADA7256J08A8U30	9ADF7256J08A8U30	9ADA7K56J08A8U30	9ADF7K56J08A8U30
10 (394)	0.8 (5.2)	2000	200	5	9ADA8256J08B0U30	9ADF8256J08B0U30	9ADA8K56J08B0U30	9ADF8K56J08B0U30

Heaters with change in power when temperature rises (PTC, positive temperature coefficient)								
A Length m (inch)	Power density W/cm ² (W/in ²)	Total Power** Watts	Power per meter W/m	PTC curve	Part numbers with antifreeze thermostat at 4°C, without adhesive, without K sensor	Part numbers with antifreeze thermostat at 4°C, with adhesive, without K sensor	Part numbers without antifreeze thermostat at 4°C, without adhesive, with K sensor	Part numbers without antifreeze thermostat at 4°C, with adhesive, with K sensor
2,5 (98.5)	0.1 (0.65)	60	25	6	9ADA1261B5806U30	9ADF1261B5806U30	9ADA1K61B5806U30	9ADF1K61B5806U30
2,5 (98.5)	0.2 (1.3)	120	50	6	9ADA2261B5812U30	9ADF2261B5812U30	9ADA2K61B5812U30	9ADF2K61B5812U30
2,5 (98.5)	0.3 (1.9)	180	75	6	9ADA3261B5818U30	9ADF3261B5818U30	9ADA3K61B5818U30	9ADF3K61B5818U30
2,5 (98.5)	0.4 (2.6)	250	100	6	9ADA4262B5825U30	9ADF4262B5825U30	9ADA4K62B5825U30	9ADF4K62B5825U30
2,5 (98.5)	0.5 (3.2)	310	125	6	9ADA5262B5831U30	9ADF5262B5831U30	9ADA5K62B5831U30	9ADF5K62B5831U30
2,5 (98.5)	0.6 (3.9)	370	150	6	9ADA6262B5837U30	9ADF6262B5837U30	9ADA6K62B5837U30	9ADF6K62B5837U30
2,5 (98.5)	0.7 (4.5)	430	175	6	9ADA7263B5843U30	9ADF7263B5843U30	9ADA7K63B5843U30	9ADF7K63B5843U30
2,5 (98.5)	0.8 (5.2)	500	200	6	9ADA8263B5850U30	9ADF8263B5850U30	9ADA8K63B5850U30	9ADF8K63B5850U30
5 (197)	0.1 (0.65)	120	25	10	9ADA12A1E0812U30	9ADF12A1E0812U30	9ADA1KA1E0812U30	9ADF1KA1E0812U30
5 (197)	0.2 (1.3)	250	50	10	9ADA22A1E0825U30	9ADF22A1E0825U30	9ADA2KA1E0825U30	9ADF2KA1E0825U30
5 (197)	0.3 (1.9)	370	75	10	9ADA32A2E0837U30	9ADF32A2E0837U30	9ADA1KA2E0837U30	9ADF3KA2E0837U30
5 (197)	0.4 (2.6)	500	100	10	9ADA42A2E0850U30	9ADF42A2E0850U30	9ADA4KA2E0850U30	9ADF4KA2E0850U30
5 (197)	0.5 (3.2)	620	125	10	9ADA52A2E0862U30	9ADF52A2E0862U30	9ADA5KA2E0862U30	9ADF5KA2E0862U30
5 (197)	0.6 (3.9)	750	150	10	9ADA62A2E0875U30	9ADF62A2E0875U30	9ADA6KA2E0875U30	9ADF6KA2E0875U30
5 (197)	0.7 (4.5)	870	175	10	9ADA72A2E0887U30	9ADF72A2E0887U30	9ADA7KA2E0887U30	9ADF7KA2E0887U30
5 (197)	0.8 (5.2)	990	200	10	9ADA82A2E0899U30	9ADF82A2E0899U30	9ADA8KA2E0899U30	9ADF8KA2E0899U30
10 (394)	0.1 (0.65)	250	25	10	9ADA12A2J0825U30	9ADF12A2J0825U30	9ADA1KA2J0825U30	9ADF1KA2J0825U30
10 (394)	0.2 (1.3)	500	50	10	9ADA22A2J0850U30	9ADF22A2J0850U30	9ADA2KA2J0850U30	9ADF2KA2J0850U30
10 (394)	0.3 (1.9)	750	75	10	9ADA32A3J0875U30	9ADF32A3J0875U30	9ADA3KA3J0875U30	9ADF3KA3J0875U30
10 (394)	0.4 (2.6)	1000	100	10	9ADA42A3J08A0U30	9ADF42A3J08A0U30	9ADA4KA3J08A0U30	9ADF4KA3J08A0U30
10 (394)	0.5 (3.2)	1250	125	10	9ADA52A5J08A3U30	9ADF52A5J08A3U30	9ADA5KA5J08A3U30	9ADF5KA5J08A3U30
10 (394)	0.6 (3.9)	1500	150	10	9ADA62A5J08A5U30	9ADF62A5J08A5U30	9ADA6KA5J08A5U30	9ADF6KA5J08A5U30
10 (394)	0.7 (4.5)	1750	175	10	9ADA72A6J08A8U30	9ADF72A6J08A8U30	9ADA7KA6J08A8U30	9ADF7KA6J08A8U30
10 (394)	0.8 (5.2)	2000	200	10	9ADA82A6J08B0U30	9ADF82A6J08B0U30	9ADA8KA6J08B0U30	9ADF8KA6J08B0U30

* - 2 x 0.75mm² (AWG18) cord, PVC insulated, length 3m, with UL plug instead of Euro plug, replace U30 by R30 in the part number.

- 3 x 1mm² (AWG16) cord, rubber insulated, length 3m, Euro plug, replace U30 by C30 in the part number

- 3 x 1mm² (AWG16) cord, rubber insulated, length 3m, UL plug, replace U30 by D30 in the part number.

- 2 x 0.75mm² (AWG18) wires, FEP insulated, 500mm long instead of euro plug with 3 meters cord, replace U30 by 450 in the part number

- 3 x 1.5mm² (AWG16) rubber insulated cable, 3 m long, without plug, replace U30 by A30 in the part number

** Values above 2000W are not compatible with this series

*** 2.5mm thickness instead 1.6mm, replace 9ASA by 9ADB or 9ADF by 9ADG in the part number.

Because of permanent improvement of our products, drawings, descriptions, features used on these data sheets are for guidance only and can be modified without prior advice

