

Slow action contact miniature pressure switches for printed circuit boards with 5 mm pitch, metal fitting

SPNC contact : Type ZE

DIMENSIONS

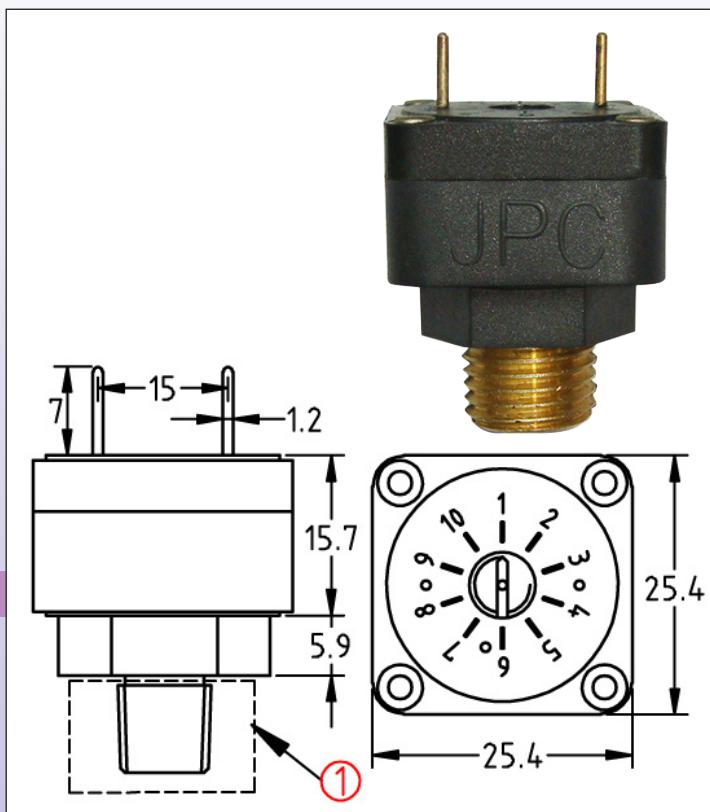

Uses: Low voltage, high sensitivity
Main applications: Electronic printed circuit. This pressure switch is more sensible than snap action models and can be calibrated at lower pressure values. Very small differential.
Membranes: EPDM, dia 22 mm. Silicone or NBR on request
Fluid: water or air
Fitting: Brass (stainless steel on request)
Pressure: positive
Housing: PA66, UL94 VO
Contact: single pole normally close, slow break.
Electrical rating:
 - Silver contact: max 1A 250V
 - Gold plated contact: max 100 mA, 24V
Action: momentary, open on pressure rise.
Set point calibration: factory calibrated and sealed, not field adjustable
Set point calibration limits: standard calibration 50mbar, other values are achievable from 20 to 400 mbar
Electrical connection: printed circuit terminal, dia 1.2 mm, 15 mm spacing
Maximum pressure: 2 bars (29 PSI)
Ambient temperature limits: 0 to 85°C

Available pressure inlet fittings ①

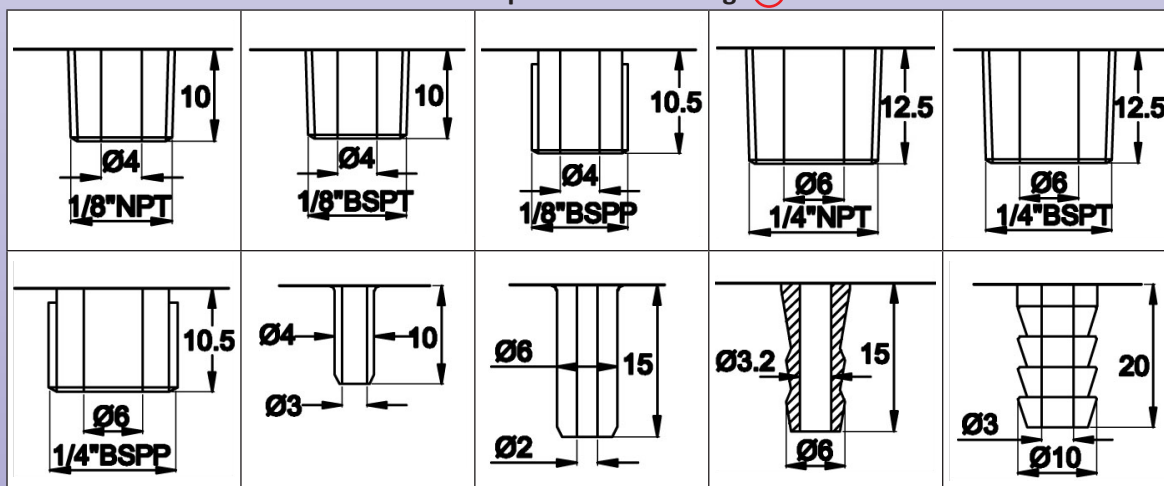

References (with calibration at 50 mbar and brass fitting):

Pressure inlet	Silver contact	Gold plated contact
1/8" NPT	ZE2X1RL105000000	ZE2X1RLG050000000
1/8" BSPT	ZE2X1PL105000000	ZE2X1PLG050000000
1/8" BSPP	ZE2X1LL105000000	ZE2X1LLG050000000
1/4" NPT	ZE2X1CL105000000	ZE2X1CLG050000000
1/4" BSPT	ZE2X1SL105000000	ZE2X1SLG050000000
1/4" BSPP	ZE2X12L105000000	ZE2X12LG050000000
Smooth spout dia 4 mm	ZE2X13L105000000	ZE2X13LG050000000
Spout dia 6 mm	ZE2X17L105000000	ZE2X17LG050000000
Fluted spout dia 6 mm	ZE2X1JL105000000	ZE2X1JLG050000000
Barbed spout dia 10 mm	ZE2X19L105000000	ZE2X19LG050000000

Other set point values: replace 050 in the product reference by the requested value in mbar

