

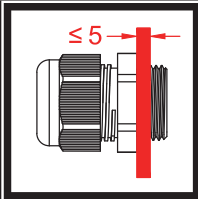

M20 cable gland, short thread, Nickel plated brass, IP66, Ex "e", self-locking, for round cables from 3.5 to 12mm

Material	Gaskets	Wall		Models
Nickel plated brass	NBR			6YTX





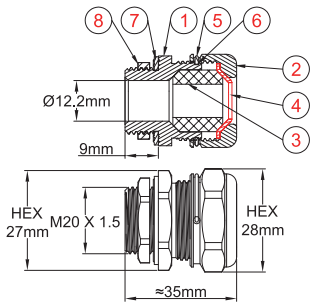
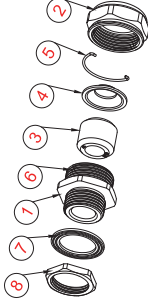

1: Nickel plated brass body
 2: Nickel plated brass compression nut
 3: NBR filling
 4: Compression washer, stainless steel 304
 5: Locking spring, stainless steel 304
 6: Locking blind holes
 7: NBR flat gasket
 8: Nickel plated brass counter nut

This cable gland has been developed for applications in explosion-proof enclosures with increased safety. The reduced length of the thread makes it possible to mount it in boxes with thin walls, without too much encroaching on the interior space. **Its main feature (patented) is to guarantee the minimum required tightening torque and to automatically block the rotation of the nut when it is reached.** This system also locks the nut and makes loosening impossible by vibration or unauthorized personnel.

NB: This locking spring can be easily removed if its use is not required.

It allows to pass cable diameters from 3.5mm up to 12mm. Made of nickel-plated brass with stainless steel locking spring. NBR 70 shore gaskets and Aisi 304 stainless-steel washers. Temperature limits -40°C + 110°C. (-40°F + 230°F).





Supplied without M20x1.5 nickel plated brass nut and without external flat gasket (They must be ordered separately).

Main references

Cable diameters*	References	Cable diameters*	References
3.5 ~ 4mm	6YTXAM20S035040N	8 ~ 10mm	6YTXAM20S080100N
4 ~ 6mm	6YTXAM20S040060N	10 ~ 11mm	6YTXCM20S100110N
6 ~ 8mm	6YTXAM20S060080N	11 ~ 12mm	6YTXCM20S110120N

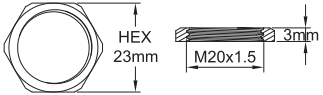
* : Internal gaskets and washers are marked with usable cable diameters.

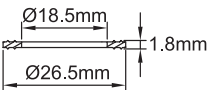
Spare parts

Description	Drawing	Picture	References
Counter nut, nickel plated brass			66NKM24535H23
External flat gasket, NBR 70 shore, black			66JPN18518265
External flat gasket, silicone 65 shore, black			66JPT18518265

Excerpt from catalogue 10-2



Page (.pdf)



Drawing 2D (.dwg)



Drawing 3D (.stp)

