

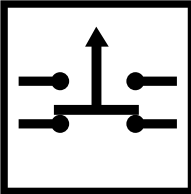

Electric fire detection switches with thermal glass bulb or fusible link, wall mounting

P1

Double break SPDT	Rating	Manual reset	Wall mounting		Models
	16A 250V 10A 400V 4A 24V DC				59A7, 59B7

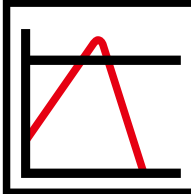
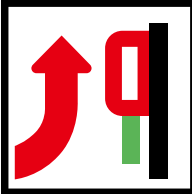

59A7 (Thermal glass bulb)

59B7 (Fusible link)

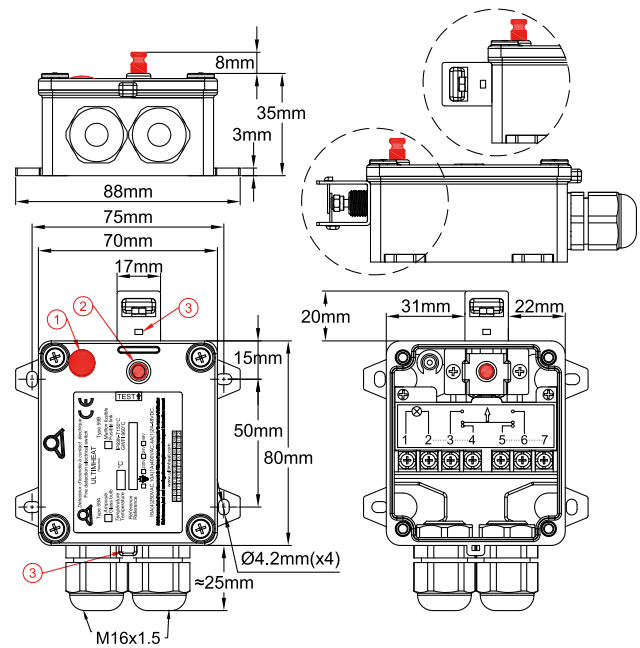
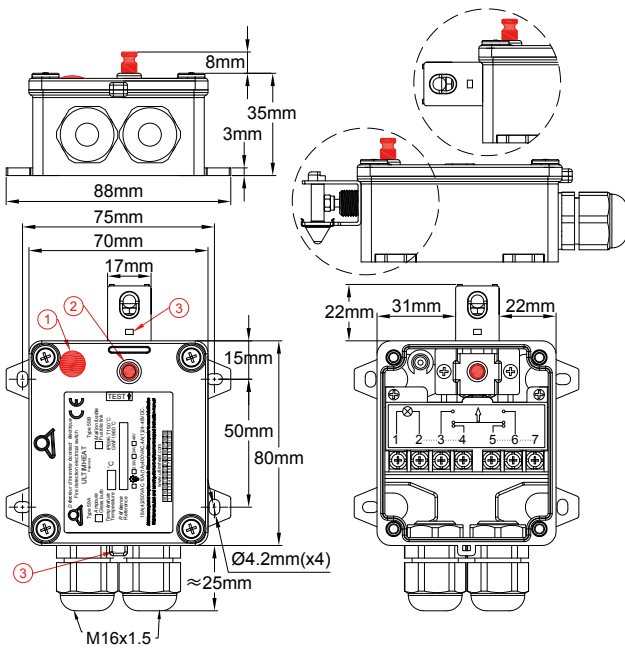

59A7 (Thermal glass bulb)

59B7 (Fusible link)

- 1: Pilot light (option)
- 2: Test button (option)
- 3: security seal holes

- 1: Pilot light (option)
- 2: Test button (option)
- 3: security seal holes

Applications

Fire detection in buildings. This device operates electrical contacts for remote alarm and simultaneous control of electrical servo-controls such as electric cylinders, electric motors or solenoids, for opening or closing air conditioning dampers, doors, sunroofs, and openings in exterior building walls.

Main Features

Thermal sensitive part: Thermo-breakable bulb or eutectic alloy link.

Operation: The break of the bulb or the melting of the fusible link activates, by means of a ceramic pusher, an electric switch.

Mounting: Enclosure with 4 **removable** legs, allowing mounting on the wall or ceiling. If the mounting is done on a particular board, removing the 4 legs on the back provides access to 4 M4 threads available for

Because of permanent improvement of our products, drawings, descriptions, features used on these data sheets are for guidance only and can be modified without prior advice



Electric fire detection switches with thermal glass bulb or fusible link, wall mounting

this purpose.

Orientation: The temperature-sensitive part (glass bulb or fusible link) is mounted on a stainless-steel support that can be rotated every 90° to position it in the most favourable direction to the air flow.

Electrical contact: Double snap action contact with two independent circuits, one normally open and the other normally closed. Total contact spacing is larger than 3mm, providing full disconnection upon IEC standards.

Electrical rating: 16A (4A) 250VAC; 10A (1A) 400VAC; 4A (100mA) 24 and 48VDC. Compatible with electric door magnets in 24V and 48V, 500 N.

(Version with gold plated contacts for low level electronic circuits available on request).

Enclosure: 70 x 80 x 45mm in UV resistant black PA66, with captive lid screws in stainless steel.

- Flammability: UL94V0 and GWFI 960°C.
- Deformation temperature under load: 225°C. (ISO 75-2, 1.8 MPa).
- Ambient temperature class T150°C.
- Resistance to corrosion better than 1000 hours in salt spray fog at 5%.
- Ingress resistance: The highest class, IP69K (washable at high pressure hot water cleaner).
- Impact resistance: The highest class, IK10 (except stainless steel support for temperature-sensitive parts and glass bulbs).

Electrical connection: On screw terminal block, 7 terminals 2.5mm². Shipped with a 3-way shunt and a 2-way shunt, allowing different contact and connection arrangement solutions. Cable outlet by two M16 cable glands.

Maintenance:

- Replacement of the temperature-sensitive part can be made without tools
- A test button (option) accessible from the outside allows to check instantly the operation of the switch without any disassembly or opening.
- The enclosure has holes for the installation of seals preventing unauthorized opening.
- Temperature sensitive parts may also be sealed to prevent unauthorized replacement.

Visualization: Optional 230 V, 24V or 48V pilot light. **This pilot light can be used to visualize the presence of voltage on the line, a critical parameter for "contact closes on fire" detection systems.**

Rod type sensor: This device, in the thermal bulb version, is also available with a rod-type sensor for wall-mounted air duct use (see type 59A8).

Other options: Customization and customer labelling. Output by a single cable gland.

Wiring diagrams

<p>Contact opens when the device triggers.</p>	
<p>Wiring in serial of devices whose contact opens when the device triggers.</p>	
<p>Contact opens circuit 1 when the device triggers, and closes circuit 2 for alarm. The 2 circuits may have different voltages.</p>	
<p>Contact closes when the device triggers.</p>	
<p>Wiring in serial of devices whose contact closes when the device triggers.</p>	

Because of permanent improvement of our products, drawings, descriptions, features used on these data sheets are for guidance only and can be modified without prior advice



Electric fire detection switches with thermal glass bulb or fusible link, **wall mounting**

P3

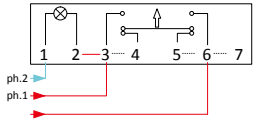
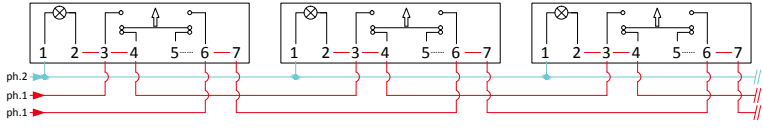
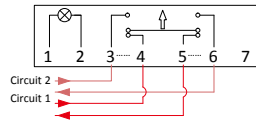
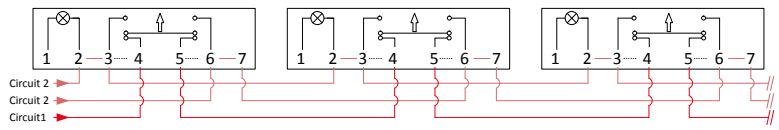
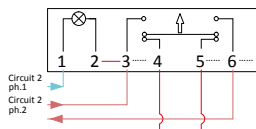
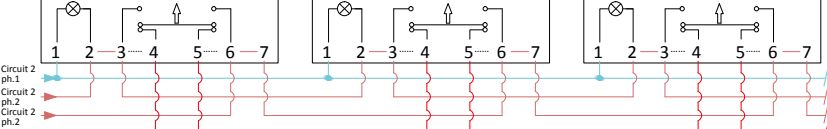
<p>Contact closes when the device triggers, with pilot light showing that power supply is on.</p>	
<p>Connection in parallel of many devices with contact closes when the device triggers, with pilot light showing that power supply is on.</p>	
<p>Serial connection of open on trigger contact (Circuit 1) and in parallel of close on trigger contact (Circuit 2). The 2 circuits may have different voltages.</p>	
<p>Connection of many devices in serial of open on trigger contacts (Circuit 1) and in parallel of close on trigger contacts (Circuit 2). The 2 circuits may have different voltages.</p>	
<p>Serial connection of open on trigger contact (Circuit 1) and in parallel of close on trigger contact (Circuit 2), with pilot light on circuit 2 showing that power supply is on. The 2 circuits may have different voltages.</p>	
<p>Connection of many devices in serial of open on trigger contacts (Circuit 1) and in parallel of close on trigger contacts (Circuit 2), with pilot light on circuit 2 showing that power supply is on. (The 2 circuits may have different voltages).</p>	

Main references

Thermal glass bulb types (Type 59A)

Operating temperature	Reference without test button, without pilot light	Reference without test button, with 230V pilot light*	Reference with test button, without pilot light	Reference with test button and 230V pilot light**
Without thermal bulb	59A70PS1630003C	59A71PS1630003C	59A7AP2S1630003C	59A7BP2S1630003C
57°C (135°F) orange color bulb	59A70PS1630573C	59A71PS1630573C	59A7AP2S1630573C	59A7BP2S1630573C
68°C (155°F) red color bulb	59A70PS1630683C	59A71PS1630683C	59A7AP2S1630683C	59A7BP2S1630683C
79°C (174°F) yellow color bulb	59A70PS1630793C	59A71PS1630793C	59A7AP2S1630793C	59A7BP2S1630793C
93°C (199°F) green color bulb	59A70PS1630933C	59A71PS1630933C	59A7AP2S1630933C	59A7BP2S1630933C
141°C (286°F) blue color bulb	59A70PS1631413C	59A71PS1631413C	59A7AP2S1631413C	59A7BP2S1631413C

Because of permanent improvement of our products, drawings, descriptions, features used on these data sheets are for guidance only and can be modified without prior advice



Electric fire detection switches with thermal glass bulb or fusible link, **wall mounting**

Eutectic alloy fusible link device (Type 59B)

Operating temperature	Reference without test button, without pilot light	Reference without test button, with 230V pilot light*	Reference with test button, without pilot light	Reference with test button and 230V pilot light**
Without fusible link	59B70PS1630003C	59B71PS1630003C	59B7AP2S1630003C	59B7BP2S1630003C
70°C (158°F), non RoHS alloy	59B70PS1630703C	59B71PS1630703C	59B7AP2S1630703C	59B7BP2S1630703C
72°C (162°F), RoHS alloy	59B70PS1630723C	59B71PS1630723C	59B7AP2S1630723C	59B7BP2S1630723C
92°C (198°F), non RoHS alloy	59B70PS1630923C	59B71PS1630923C	59B7AP2S1630923C	59B7BP2S1630923C
96°C (205°F), non RoHS alloy	59B70PS1630963C	59B71PS1630963C	59B7AP2S1630963C	59B7BP2S1630963C
138°C (280°F), RoHS Alloy	59B70PS1631383C	59B71PS1631383C	59B7AP2S1631383C	59B7BP2S1631383C

- * - For models **without** test button with 24V pilot light, replace 1P by 2P in the reference
- For models **without** test button with 48V pilot light, replace 1P by 3P in the reference
- ** - For models **with** test button with 24V pilot light, replace BP by CP in the reference
- For models **with** test button with 48V pilot light, replace BP by DP in the reference

Spare parts references*

Thermal glass bulbs for 59A7 (Packing units 50 and 250p)			Eutectic alloy fusible links for 59B7 (Packing units 50 and 250p)		
	57°C (135°F)	6658GBB057		70°C (158°F), non RoHS alloy	5E6070H080000000
	68°C (155°F)	6658GBB068		72°C (162°F), RoHS alloy	5E6072H080R00000
	79°C (174°F)	6658GBB079		92°C (198°F), non RoHS alloy	5E6072H092000000
	93°C (199°F)	6658GBB093		96°C (205°F), non RoHS alloy	5E6072H096000000
	141°C (286°F)	6658GBB141		138°C (280°F), RoHS Alloy	5E6072H138R00000

* Maintenance or replacement of thermal bulbs or fusible links must be made by specially trained personnel and in accordance with our technical instructions.

Because of permanent improvement of our products, drawings, descriptions, features used on these data sheets are for guidance only and can be modified without prior advice

