

Breakable glass bulb fire detection link, miniature type

Material	Max Force		Hole distance	Models
Galvanized steel	 100 DaN		56MM	58L

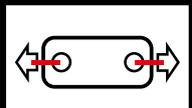
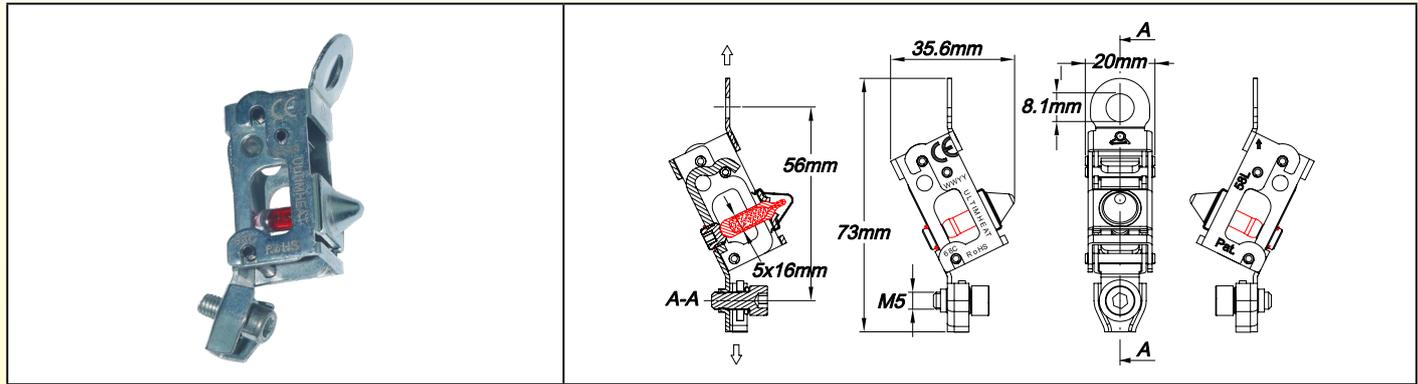

Applications

Patented mechanical system of fire detection by liquid filled glass bulb breaking. In case of fire, when the temperature reaches the liquid boiling temperature, it causes the explosion of the glass bulb, which releases the mechanism. This self-powered mechanism does not require power supply such as electricity or compressed air. It can open smoke vents, skylights, in buildings, but also actuates fire doors, air conditioning dampers, store curtains, flammable gas or liquid valves, range hood exhausts, paint and solvent exhaust fans and dampers, etc.

Dimensions: Very small foot print, can replace most of devices using fusible links. In addition, having a very high tensile strength, this device does not require a demultiplying system.

Creep sensitivity: Insensitive to creep, even close to the tripping temperature.

ROHS compliance: For most of temperature calibration, fusible fire detection systems cannot be achieved, as they use alloys containing lead and cadmium, materials that are not allowed by the RoHS standard. This glass bulb operated device does not use fusible alloy and therefore contains no prohibited metal and meets the RoHS standard.

Material: Galvanized steel

Fail safe operation: When opening, the internal lever falls unhindered by any other part, irreversibly releasing the two halves of the mechanism.

This mechanism has no spring because, due to their susceptibility to corrosion and to permanent deformation, the use of springs may cause a malfunction.

Glass bulbs: Dia. 5mm, 16mm nominal length, filled with alcohol blends.

Response time index (RTI) of bare bulbs: <25 m.s^{1/2}

Maximum permanent load: 100 DaN Tensile strength at break: ≥ 150 DaN

Minimum load: 5 DaN

Nominal opening temperatures: 57 °C (135 °F) orange bulb; 68 °C (155° F) red. The bulb coloring complies with EN 12259-1 and ISO 6182-1 international standards for color/temperature ratings. Other temperatures, consult us.

Mounting: This model features

- one side with a hole allowing the connection either on a cable, or on a bracket integral with the opening (available as accessories)

- **One side with integrated clamping device on steel cable, simplifying assembly.**

Mounting position: When used in vertical position, the glass bulb must be downside. No preferential position when mounted horizontally.

Options: Rope thimble assembled on the 8mm hole

Glass bulb replacement: Replacement is possible, by using a locking pin, which must be removed after bulb replacement.

Certifications: according to ISO 10294-4.

Because of permanent improvement of our products, drawings, descriptions, features used on these data sheets are for guidance only and can be modified without prior advice



Breakable glass bulb fire detection link, miniature type

Main references

Temperature (°C/°F)	Dia. 8mm holes without rope thimble	Dia. 8mm holes with rope thimble
57°C (135°F)	58LFF08250B057C0	58LFF08250B057C2
68°C (155°F)	58LFF08250B068C0	58LFF08250B068C2

Replacement of glass bulb (when requested by preventive maintenance rules)

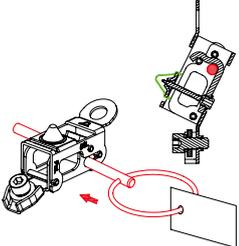
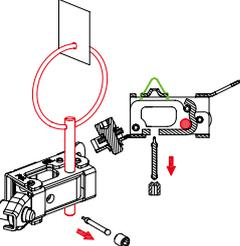
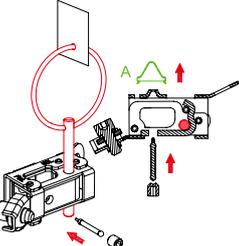
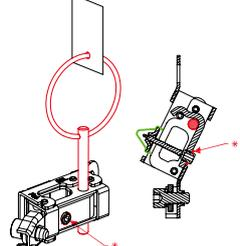
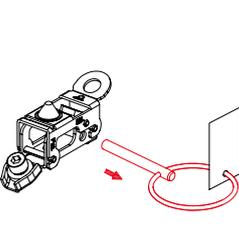
				
<p>Glass bulb replacement must be made by trained technicians. Only genuine glass bulbs with the same calibration temperature must be used.</p> <p>1/ Check the reference printed on the product (58Z or 58L). Secure the link with this pin before and during glass bulb replacement.</p>	<p>2/ Remove the screw with hexagonal key wrench. Size is 2.5mm for 58L, and 1/8 inch, (3.17mm) for 58Z. Remove the old glass bulb.</p>	<p>3/ Put carefully a new glass bulb inside (Dia.5mm). Put the screw and tighten lightly it by hand. Don't break the bulb filling needle. If any doubt, unclip the bulb needle cap (A) with a small screw driver, and check visually that the filling needle is not broken. Do not miss to clips again the cap after inspection.</p>	<p>4/ Tighten the screw with a torque controlled wrench. (Torque must be 0.5-0.6N.m.) Seal the screw thread* with a low strength sealant like Loctite 222. Be careful to not glue the lever to the frame with excess sealant.</p>	<p>5/ Important: Don't miss to remove the safety pin when you have finished.</p>