

Flap flow switches, reed switch contact, 1/2" BSPP male thread, with triac cooler, Type: R21

Pressure and size	Flow sensing: Magnetic flap	Mounting: 1/2" male thread and snap-in dia. 8 mm	Contact: Reed switch, close on flow rise	Electrical rating	Mounting position	Type
PN10 DN8				≤1A ≤70W ≤250V~		R21

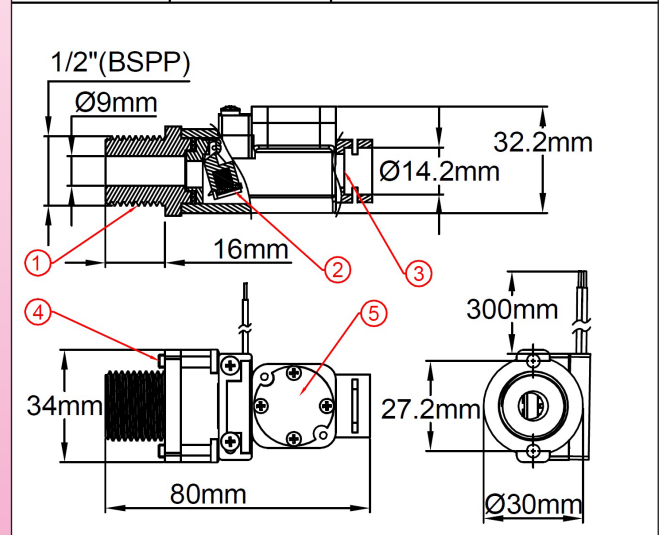
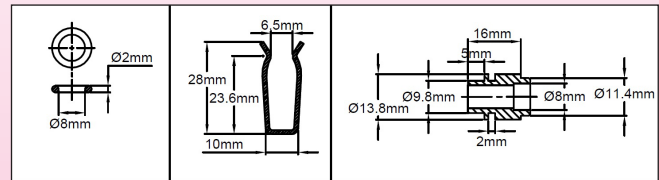
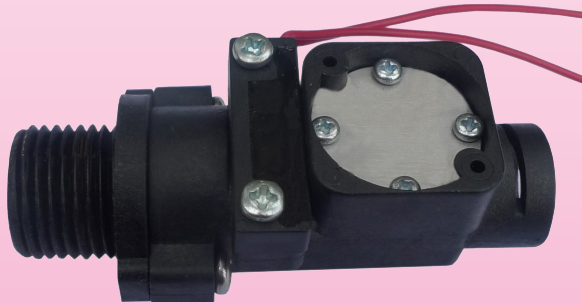

- 1: Water Inlet thread
- 2: Flow detection flap
- 3: Water outlet
- 4: Anti rotation lugs
- 5: Aluminum cooler plate for triac

Main applications: Product developed for miniature instantaneous water heaters for showers. The mobile flap system provides compactness. Water inlet is done directly by the 1/2" BSPP male thread. Mandatory vertical mounting, with water inlet from the bottom. Connection to internal copper piping DN8 and DN10 with quick coupling. **A built in aluminum heat exchanger, in contact with the cold water input is provided to cool a triac.**

Functional principle:

Magnetic flap mounted perpendicular to the flow and activating a reed switch through the wall. The return of the flap is by made by gravity, without spring. No seal or liquid can pass between the piping system and the electrical contact. Suitable for potable water. Must not be used for water containing magnetic particles or high viscosity liquids, which block the movement of the flap.

Adjustment: Can be factory set by adjusting the counterweight mounted in the flap

Body material: PPO compatible with drinking water.

Flap: PPO

Paddle shaft: stainless steel

Electrical rating: Max 1A, Max 70W, Max 250V, resistive load. Use on inductive circuits reduces electrical rating. We recommend to protect the reed switch with contact protection device when used in inductive loads

Electric contact type: Normally open, closes by flow rise

Liquids compatibility: For use with clean water and liquids without magnetic particles and without chemical incompatibility with PPO and stainless steel

Nominal pressure at 20°C: 1MPa (PN10)

Flow detection set point factory setting limits:

Close by flow rise: 1.8 to 3 L/min

Open by flow decrease: About 0.4 to 0.5L/min lower than close value

Nominal diameter: DN8-DN10

Mandatory mounting position: on vertical pipes, upstream flow

Water pipe connection:

- Water inlet: on male 1/2" fitting with gasket with 2 anti-rotation lugs. recommended torque 5N.m

- Water outlet: fast-on connection with O-ring and clips on DN8 or DN10 copper tubes with brazed or welded brass termination.

Liquids temperature range: 5 to 80°C

Ambient temperature range: 5 to 50°C

Ingress protection: IP65

Electrical connection: 2 x AWG24 wires (0.2mm²), PVC insulation, T80°, standard length 300 mm.

Accessories: brass terminations for brazing or soldering on other pipe diameters : see last section of this catalogue

Options (MOQ apply): cable with connector or terminals, other cable length, other calibration values.

Important note: Standard copper tube diameters for building applications (Water and gas) are given by the EN1057 standard, which defines the nominal diameter (DN) as the inside diameter. Copper tubes for applications in air conditioning and refrigeration are described in EN 12735-1 and those for vacuum and medical gases are described in EN 13348. The EN127357 standard defines the copper tubes for refrigeration with diameters in inches. Copper tubes are often described in France by the outside diameter followed by the thickness in mm.

Main references (with 300 mm wires)

Outlet for copper tube dia. 10 x 8 mm			Outlet for copper tube dia. 12 x 10 mm		
References	Close on flow rise (L/min)	Open on flow decrease (L/min)	References	Close on flow rise (L/min)	Open on flow decrease (L/min)
R21B670200000430	2 ±0.2	1,6±0.2	R21B680200000430	2 ±0.2	1,6±0.2
R21B670250000430	2,5±0.25	2±0.25	R21B680250000430	2,5±0.25	2±0.25
R21B670300000430	3±0.3	2,5±0.3	R21B680300000430	3±0.3	2,5±0.3

Because of permanent improvement of our products, drawings, descriptions, features used on these data sheets are for guidance only and can be modified without prior advice

