

Vertical mounting, reed switch contact, polypropylene stem with M8 thread, dia. 29x16.4 mm hollow polypropylene float, cable output , for near bottom level detection

Type DM

DIMENSIONS

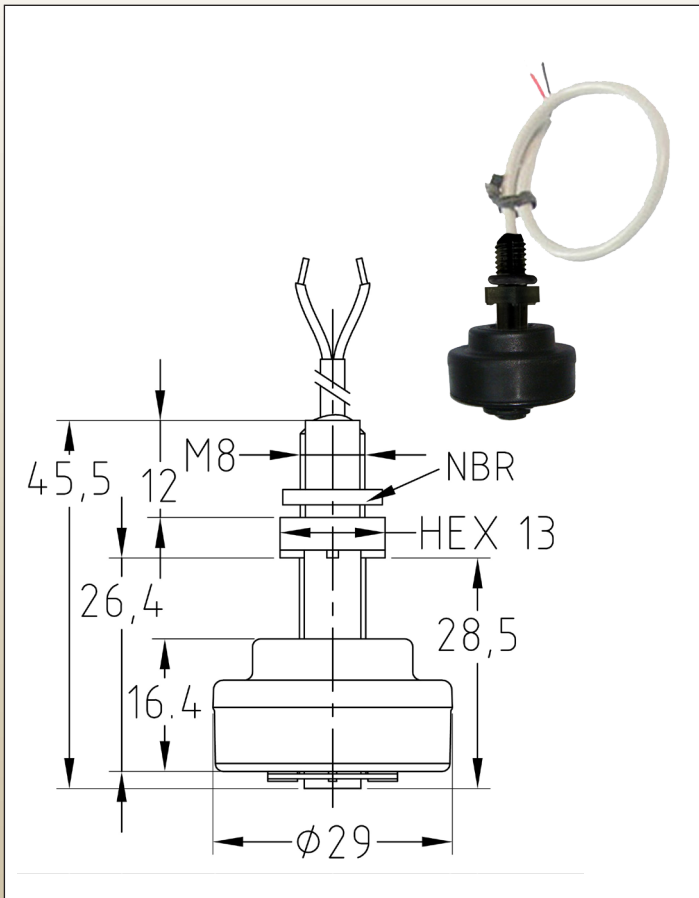

MAIN FEATURES

- Use:** low voltage circuits
- Main applications:** steam generators, coffee machines, vending machines, air conditioning pumps, dehumidifiers. Large diameter float for low water level detection
- Stem material:** polypropylene
- Float material:** hollow polypropylene
- Mounting:** vertical, throw wall, with M8 nut and flat NBR gasket
- Contact configuration:** normally closed when float is down on the stem. It opens when float goes up to the wiring side. Upsetting the float changes the contact configuration into normally open
- Electrical rating:**
Low voltage type: maximum power 10 W (VA), max 0.5Amp, max voltage 110VAC.
230VAC type: max power 40 W (VA), max 1Amp. Values for resistive circuit. For inductive or capacitive loads, a contact protection circuit must be used.
- Contact resistance:** 150mOhms maxi (wires not included)
- Wires:** AWG24 cable, UL style 2464, PVC insulated, length 100, 500, 1000 or 2000 mm
- Liquid limits:** to be used with liquids chemically compatible with polypropylene, dynamic viscosity higher than 0.5×10^{-4} Pa.s and lower than 10^{-2} Pa.s, specific gravity higher than 0.9, without magnetic particles
- Ambient temperature:** -20+80°C
- Maximum pressure:** 1 bar (15 PSI)
- Options:** other cable length, electrical rating 70W, 1A, 250VAC

References

Electrical Rating	Cable 100 mm	Cable 500 mm	Cable 1000 mm	Cable 2000 mm
10VA (max 110VAC)	DMF0F082829F1050	DMF0F082829F5050	DMF0F082829FA050	DMF0F082829FB050
40VA (max 230VAC)	DMF4F082829F1050	DMF4F082829F5050	DMF4F082829FA050	DMF4F082829FB050

Because of permanent improvement of our products, drawings, descriptions, features used on these data sheets are for guidance only and can be modified without prior advice

