

Jacket heaters with fixed setting surface mounted temperature control



Safety instructions for all industrial jacket heaters described in this catalogue

- Read the user manual before any use
- Protect the power supply circuit by a differential circuit breaker of 20mA sensitivity, with rating adapted to the model that must be connected to it.
- This supply circuit must be carried out by a qualified electrician and according to the local standards in force.
- The earth circuit must be compliant and connected.
- The jacket heater must be disconnected when the container is empty.
- The jacket heater must be disconnected when filling the container.
- The jacket heater must be disconnected during installation or de-installation.
- The jacket heater must be stored in a dry place and protected from rodents and other animals during periods when it is not used.
- In some applications and especially when liquid overflow is possible, it may be necessary to connect the metal containers directly to a grounding conductor.
- The jacket heater must be used in a dry environment.
- Do not cut or punch the surface
- The container must be in communication with the atmospheric pressure to avoid the increase of its internal pressure and its explosion by dilation or boiling of the products which it contains. This setting at atmospheric pressure may for example be performed by unscrewing or removing a plug located in the upper part of the container. The use of a temperature sensor and / or stirrer using this upper orifice for their fastenings must not completely close this orifice.
- These appliances are not suitable for permanent outdoor use, and must be protected from rain, dust and condensation.
- Do not operate above the rated safety temperature (This temperature depends on the heated liquid, and must be checked before connecting the device).
- Use a jacket heater adapted to the size of the container
- The jacket heater must be in contact with the surface of the container to be heated, without superimposing heating parts. The superposition of two heating parts doubles the surface power and can cause melting of the jacket heater and initiate a fire in the most severe cases.
- Position the jacket heater so that it is in contact with the largest possible cylindrical surface of the container.
- These devices are not suitable for use in flammable or explosive areas.



Fixed temperature setting flexible jacket heaters for glass or plastic containers

Containers materia	Maximum temperature limited to :	Tightening	Thermostat	Insulation thickness	Type
Glass, Plastic	65°C	Nylon straps and metal buckle	Surface mounted, fixed setting temperature 65°C	10mm	9VJV6

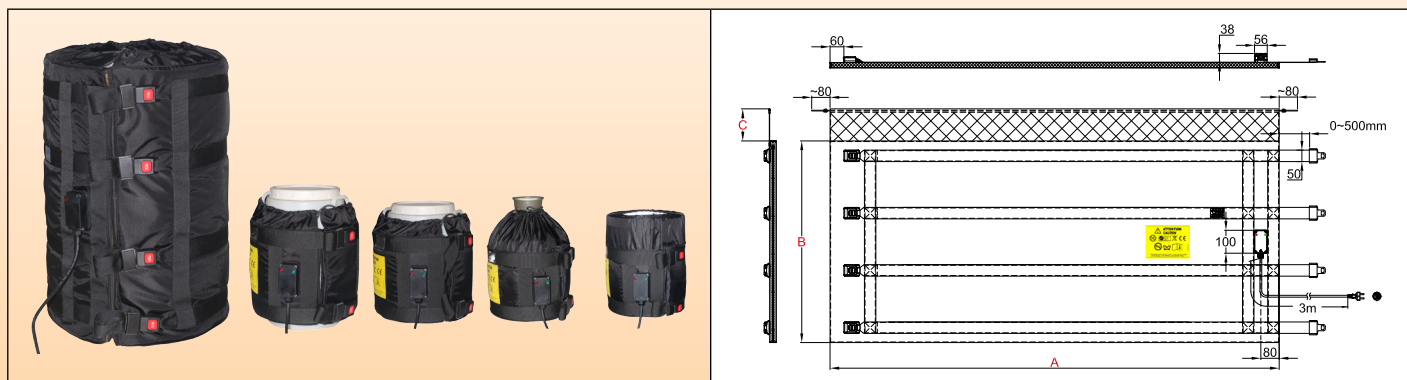

Main Features

This **economical version** of flexible jacket heater is used to reduce viscosity or to melt soaps, animal or vegetable fats, varnishes, oils, food or chemical products.

It is the most efficient solution for heating glass or plastic containers. These models are available for containers of 18L/20L (5 US gallons), 23L/25L (6 US gallons), 30L (8 US gallons), 60L (15 US gallons) and 110 liters (30 US gallons). The jacket heater covers almost the entire surface and is surmounted by a soft collar "a scarf" preventing it from sliding down. They can be made with two power levels (0.05W / cm² and 0.1W / cm²) and two thicknesses of insulation (10mm in standard and 20mm in option). In these models the surface temperature is limited to 65°C to prevent deformation or melting of plastic containers, or temperature stress breaking of glass containers.

When they are used with an insulated lid and an insulated pedestal, their energetic efficiency can rise 90%.

Technical characteristics

The heating element of the flexible jacket heater consists of a network of silicone insulated heating wires shielded by a metal braid, taken under a cover sewn in PU and Teflon coated polyester fabric. A temperature-resistant NBR-PVC foam insulation is inserted between the heating network and the outer wall. This insulating foam has an insulation coefficient (Lambda λ) of 0.039W/m.K, and this makes it possible to divide the energy losses by 3 compared to jacket heaters insulated with mineral wool or carbon fiber felt of the same thickness. Adjustable **metal** buckles allow quick assembly and disassembly and efficient clamping on the container. Their mechanical strength is exceptional.

Fabric covering:

- Internal heating face: Teflon coated polyester fabric,
- External side: waterproof PU coated polyester fabric.

Thermal insulation:

NBR-PVC foam, with closed cells and high temperature resistance, thickness 10mm. This thickness is chosen for its great flexibility, important on small containers.

Heating element:

Silicon rubber insulated heating wire with metal braid providing mechanical protection against puncturing and good grounding.

Temperature control:

A temperature limiter is incorporated in the heating net to limit the surface temperature to 65°C. Two pilot lamps indicate the presence of voltage and the heating function.

Warning: these models start to heat up as soon as you connect them to the power supply.

Connection cable:

Insulated rubber power supply cable, for industrial environments, 3 x 1mm² length 3m, Euro plug. UL plug on request.

Mounting on containers:

These jacket heaters feature nylon straps with quick-release adjustable buckles for adjustment to the diameter of the container, and a soft fabric collar without thermal insulation named scarf. This flexible scarf can be used to hold in place an insulating lid in the case of cylindrical containers.

Options:

- 0.135W/cm² surface load for fast heating. See technical introduction.
- Power supply 110/115V



Fixed temperature setting flexible jacket heaters for glass or plastic containers

- Power cord with industrial plug 2-pole + earth 16A CEE (IEC60309)

- Lids and insulated pedestals: see the accessories pages.

Compliance with standards: CE compliant. TUV certificate: EEC Low Voltage Directive (LVD) and EMC directive 2004/108/EC, and CE marked accordingly.

Main references (see the technical introduction for the liquids heating time)

References*	Insulation (mm)**	Volume, US gallons	Volume, Liters	Dia. (mm ± 12 ; Inch ± ½")	Height A (mm/inch)	Flat length B (mm/inch)	Scarf C (mm/ inch)	w/cm ² (W/in ²)	Watt	Voltage V
9VJV6300958150HC	10	5	18/20	280 (11)	300 (11.8)	950 (37.4)	150 (5.9)	0,05 (0.32)	150	220/240
9VJV6301028165HC	10	6	25/30	280 (11)	300 (11.8)	1020 (40.2)	150 (5.9)	0,05 (0.32)	165	220/240
9VJV6401398275HG	10	15	50/60	410 (16.1)	400 (15.7)	1390 (54.7)	100 (3.9)	0,05 (0.32)	275	220/240
9VJV6731558550HG	10	30	110	460 (18.1)	730 (28.8)	1550 (61)	100 (3.9)	0,05 (0.32)	550	220/240
9VJV6300958300HC	10	5	20/25	280 (11)	300 (11.8)	900 (35.4)	150 (5.9)	0,1 (0.64)	300	220/240
9VJV6301028330HC	10	6	25/30	280 (11)	300 (11.8)	1020 (40.2)	150 (5.9)	0,1 (0.64)	330	220/240
9VJV6401398550HG	10	15	50/60	410 (16.1)	400 (15.7)	1390 (54.7)	100 (3.9)	0,1 (0.64)	550	220/240
9VJV6731558A10HG	10	30	110	460 (18.1)	730 (28.8)	1550 (61)	100 (3.9)	0,1 (0.64)	1100	220/240

* For these products supplied with UL plug and not Euro plug, replace the 15th character by X.

** Models with 20mm insulation, replace 9VJV6 by 9VJF6

Because of permanent improvement of our products, drawings, descriptions, features used on these data sheets are for guidance only and can be modified without prior advice



Fixed temperature setting flexible jacket heaters for metal drums and 1000 liters IBC

Containers material	Maximum temperature limited to :	Tightening	Thermostat	Insulation thickness	Type
Metal or plastic with grid	65°C	Nylon straps and metal buckle	Surface mounted, fixed setting temperature 65°C	20mm	9VJF6

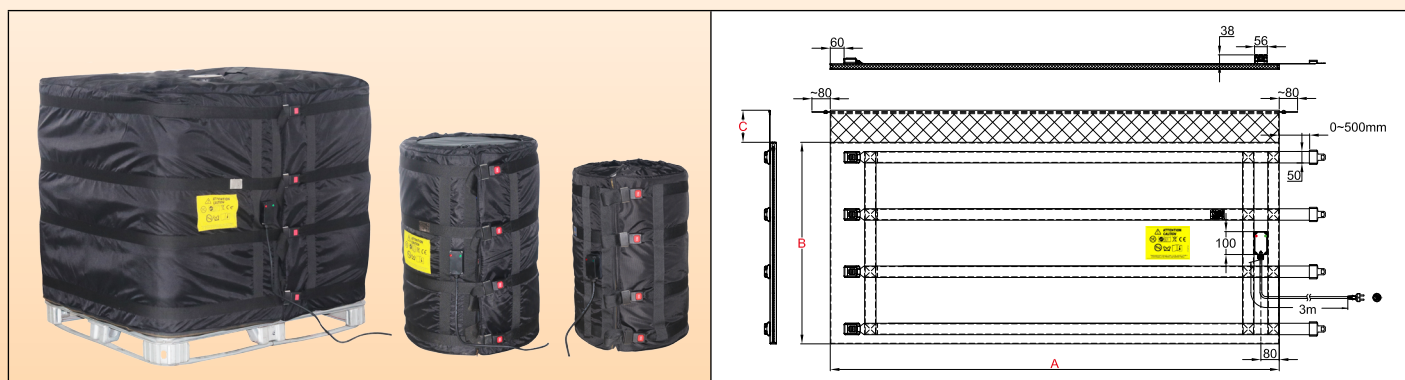

Main Features

This **economical version** of flexible jacket heater is used to reduce viscosity or to melt soaps, animal or vegetable fats, varnishes, oils, food or chemical products.

These models are available for containers of 110L (30 US gallons), 210L (55US gallons) and 1000 liters IBC. The jacket heater covers the entire surface and is surmounted by a soft collar "a scarf" preventing it from sliding down. They can be made with two power levels (0.05W / cm² and 0.1W / cm²) and insulation thicknesses of 20mm. In these models the surface temperature is limited to 65°C.

When they are used with an insulated lid and an insulated pedestal, their energetic efficiency can rise 90%.

Technical characteristics

The heating element of the flexible jacket heater consists of a network of silicone insulated heating wires shielded by a metal braid, taken under a cover sewn in PU and Teflon coated polyester fabric. A 20 mm thick, temperature-resistant NBR-PVC foam insulation is inserted between the heating network and the outer wall. This insulating foam has an insulation coefficient (Lambda λ) of 0.039W/m.K, and this makes it possible to divide the energy losses by 3 compared to jacket heaters insulated with mineral wool or carbon fiber felt of the same thickness. Four adjustable **metal** buckles allow quick assembly and disassembly and efficient clamping on the container. Their mechanical strength is exceptional.

Fabric covering:

- Internal heating face: Teflon coated polyester fabric,
- External side: waterproof PU coated polyester fabric.

Thermal insulation:

NBR-PVC foam, with closed cells and high temperature resistance, thickness 20mm.

Heating element:

Silicon insulated heating wire with metal braid providing mechanical protection against puncturing and good grounding.

Temperature control:

A temperature limiter is incorporated in the heating net to limit the surface temperature to 65°C. Two pilot lamps indicate the presence of voltage and the heating function.

Warning: these models start to heat up as soon as you connect them to the power supply.

Connection cable:

Insulated rubber power supply cable, for industrial environments, 3 x 1mm² length 3m, Euro plug. (3x1.5mm² for the IBC model). UL plug on request.

Mounting on containers:

These jacket heaters feature nylon straps with quick-release adjustable buckles for adjustment to the diameter of the container, and a soft fabric collar without thermal insulation named scarf. This flexible scarf can be used to hold in place an insulating lid.

Options:

- 0.135W/cm² surface load for fast heating. (Not available for IBC in this temperature control version). See technical introduction.
- Power supply 110/115V
- Power cord with industrial plug 2-pole + earth 16A CEE (IEC60309)
- Lids and insulated pedestals: see the accessories pages.



Fixed temperature setting flexible jacket heaters for metal drums and 1000 liters IBC

Compliance with standards: CE compliant. TUV certificate: EEC Low Voltage Directive (LVD) and EMC directive 2004/108/EC, and CE marked accordingly.

Main references (see the technical introduction for the liquids heating time)

References*	Volume, US gallons	Volume, Liters	Dia. (mm \pm 12 ; Inch \pm 1/2")	Height A (mm/inch)	Flat length B (mm/inch)	Scarf C (mm/ inch)	w/cm ² (W/in ²)**	Watt	Voltage V
9VJF6731558550HG	30	110	460 (18.1)	730 (28.8)	1550 (61)	100 (3.9)	0,05 (0.32)	550	220/240
9VJF6881898880HG	55	210	585 (23)	880 (34.6)	1890 (74.4)	100 (3.9)	0,05 (0.32)	880	220/240
9VJF6A0D398B205G	264	1000	1000 x 1200 (39.4 x 47.3)	1000 (39.4)	4390 (172.8)	100 (3.9)	0,05 (0.32)	2200	220/240
9VJF6731558A10HG	30	110	460 (18.1)	880 (34.6)	1550 (61)	100 (3.9)	0,1 (0.64)	1100	220/240
9VJF6881898550HG	55	210	585 (23)	1000 (39.4)	1890 (74.4)	100 (3.9)	0,1 (0.64)	1660	220/240

* For these products supplied with UL plug and not Euro plug, replace the 15th character by X.

** In this temperature control version 0.1W/cm² and 0.135W/cm² are not available for IBC size.

Because of permanent improvement of our products, drawings, descriptions, features used on these data sheets are for guidance only and can be modified without prior advice

